

## 8. Fixture Cleaning

The cleaning of internal and external optical lenses and/or mirrors must be carried out periodically to optimize light output. Cleaning frequency depends on the environment in which the fixture operates: damp, smoky or particularly dirty surrounding can cause greater accumulation of dirt on the unit's optics.

- ÿ Clean with soft cloth using normal glass cleaning fluid.
- ÿ Always dry the parts carefully.
- ÿ Clean the external optics at least every 20 days. Clean the internal optics at least every 30/60 days.

### EC Declaration of Conformity

We declare that our products (lighting equipments) comply with the following specification and bears CE mark in accordance with the provision of the Electromagnetic Compatibility (EMC) Directive 89/336/EEC.

EN55014-2: 1997 A1:2001, EN61000-4-2: 1995; EN61000-4-3:2002;  
EN61000-4-4: 1995; EN61000-4-5: 1995, EN61000-4-6:1996,  
EN61000-4-11: 1994.

&

### Harmonized Standard

EN 60598-1: 2004  
IEC 60598-1:2003+ corrigendum 2004  
Part 1:General requirements and test

Following the provisions of the low voltage directive 73/23/EEC and 93/68/EEC

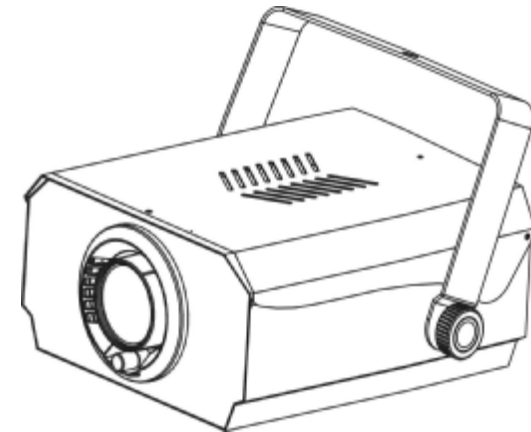

## **ME2602-1      User Guide**

Professional Entertainment Technology

**Innovation , Quality , Performance**

TABLE OF CONTENTS

- 1. Introduction
- 2. Safety Instruction
- 3. Description
- 4. Operation and Technical Specification
- 5. Lamp installation or replacement
- 6. Beam Angle
- 7. Troubleshooting
- 8. Fixture Cleaning

**7. Troubleshooting**

Problem	Probable cause(s)	Suggested remedy
No light	No power to the fixture	Check power connections
	Blown fuse	If power is applied but does not light, please check and replace fuse if necessary.
	Burned out lamp	Install new lamp.
	Fixture too hot	Allow to cool down. Improve air flow around the unit.
No action	Sound too low to activate control circuit	Increase volume.
	Electrical malfunction	Refer to service technician.

### Specification:

- Voltage: AC 120V~60Hz
- Fuse: 20mm glass 250V T6.3A
- Bulb: ELC 24V 250W
- Dimension: 306 x 263 x 140 mm
- Weight: 8 kgs

### 5. Lamp installation or replacement

- Always switch off the mains supply and never handle the lamp or luminaire when it is hot.
- Do not touch the bulb with bare hands. If this does happen, clean the lamp with denatured alcohol and wipe with a lint free cloth before installing.

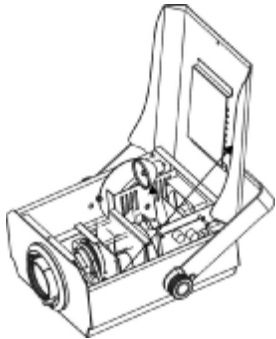

Pull the socket off the lamp.  
Do not pull the wires.

### 6. Beam angle

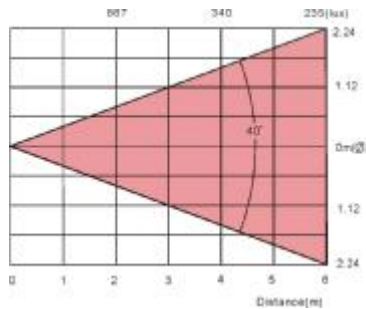

The Projector is best to be placed 5 meters from wall, and from this distance the light effect will cover an area of 3.7 m x 3.7 m.

### 1. Introduction

Thank you for purchasing Wild Tech's ME2602-1. It is a unique 250W kaleidoscopic effect that projects a swarm of swirling patterns. Comes with great built-in programs with auto movement or sound activation. It's linkable, performing synchronized light show, perfect for discos, clubs, bars, and parties.

### 2. Safety Instruction



Please read carefully the instruction, which includes important information about the installation, usage and maintenance.

#### WARNING

- ◆ Please keep this User Guide for future consultation. If you sell the unit to another user, be sure that they also receive this instruction booklet.
- ◆ Unpack and check carefully there is no transportation damage before using the unit.
- ◆ Before operating, ensure that the voltage and frequency of power supply match the power requirements of the unit.
- ◆ It's important to ground the yellow/green conductor to earth in order to avoid electric shock.
- ◆ The unit is for indoor use only. Use only in a dry location.
- ◆ The unit must be installed in a location with adequate ventilation, at least 50cm from adjacent surfaces. Be sure that no ventilation slots are blocked.
- ◆ Disconnect mains power before fuse/lamp replacement or servicing.
- ◆ Replace fuse/lamp only with the same type.
- ◆ Make sure there is no flammable materials close to the unit while operating as it is fire hazard.
- ◆ Use safety cable when fixes this unit.
- ◆ Maximum ambient temperature is TA: 40°C. Don't operate it where the temperature is higher than this.
- ◆ Unit surface temperature may reach up to 85°C. Don't touch the housing bare-hand during its operation. Turn off the power and allow about 15 minutes for the unit to cool down before replacing bulb or serving.

- ◆ In the event of serious operating problem, stop using the unit immediately. Never try to repair the unit by yourself. Repairs carried out by unskilled people can lead to damage or malfunction. Please contact the nearest authorized technical assistance center. Always use the same type spare parts.
- ◆ Don't connect the device to any dimmer pack or power pack.
- ◆ Do not touch any wire during operation as high voltage might be causing electric shock.

**Warning**

- ◆ To prevent or reduce the risk of electrical shock or fire, do not expose the unit to rain or moisture.
- ◆ Never touch bulb with bare fingers as it is very hot after using.
- ◆ Hot lamp explosion hazard. Do not open the unit within five minutes after switching off.
- ◆ Do not start on the unit without bulb enclosure or housing are damaged.
- ◆ The housing, the lenses, or the ultraviolet filter must be replaced if they are visibly damaged.
- ◆ Do not look directly at the light while the bulb is on.

**Caution**

There are no user serviceable parts inside the unit. Do not open the housing or attempt any repairs yourself. In the unlikely event your unit may require service, please contact your nearest dealer.

**Rigging the fixtures**

The unit should be mounted via its screw holes on the bracket. Always ensure that the unit is firmly fixed to avoid vibration and slipping while operating. Always ensure that the structure to which you are attaching the unit is secure and is able to support a weight of 10 times of the unit's weight. Also always use a safety cable that can hold 12 times of the weight of the unit when installing the fixture.

The installation must be carried out by qualified service people only. The device should be installed out of reach of people and outside areas where persons may walk by or be seated.

**3. Description**

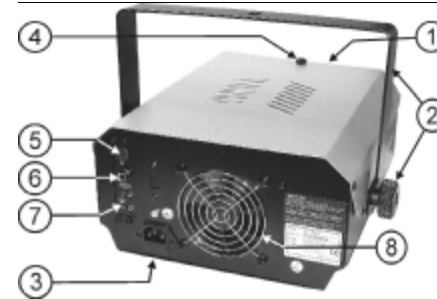

1. Optical lens with manual focus adjustment.
2. Hanging bracket with 2 knobs on both sides to fasten the unit and a mounting hole to fix a mounting hook.
3. Mains input with CIE socket and integrated fuse holder, connect the supplied mains cable here.
4. Lamp compartment, to be opened with this knob
5. Internal microphone
6. 1/4" jack used to connect the optional CA-8 controller.
7. Two 3.5mm stereo jacks used to synchronize several units.
8. Cooling fan.

**4. Operation and Technical Specification**

- Plugging into the mains power, the fixture starts running. The ME2602-1 runs in automatic or sound activated mode.
- Precise optics with special gobo / color wheel.
- Linkable by using stereo cable with 3.5mm stereo jack ( optional )
- Focus adjustable and fan cooled.
- With easy controller CA-8 ( Optional ) for many lighting shows as listed below.

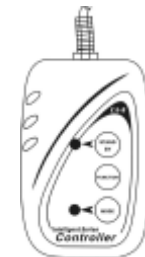

Stand by	Blackout the unit		
Function	Speed of gobo wheel and mirrored-tunnel: Fast and slow	Speed of gobo wheel and mirrored-tunnel: Fast and slow	a.) Adjust gobo wheel rotating direction and speed. b.) Adjust mirrored-tunnel rotating direction and speed.
Mode	Sound (LED off )	Auto (LED on)	Latch (LED blinking)